

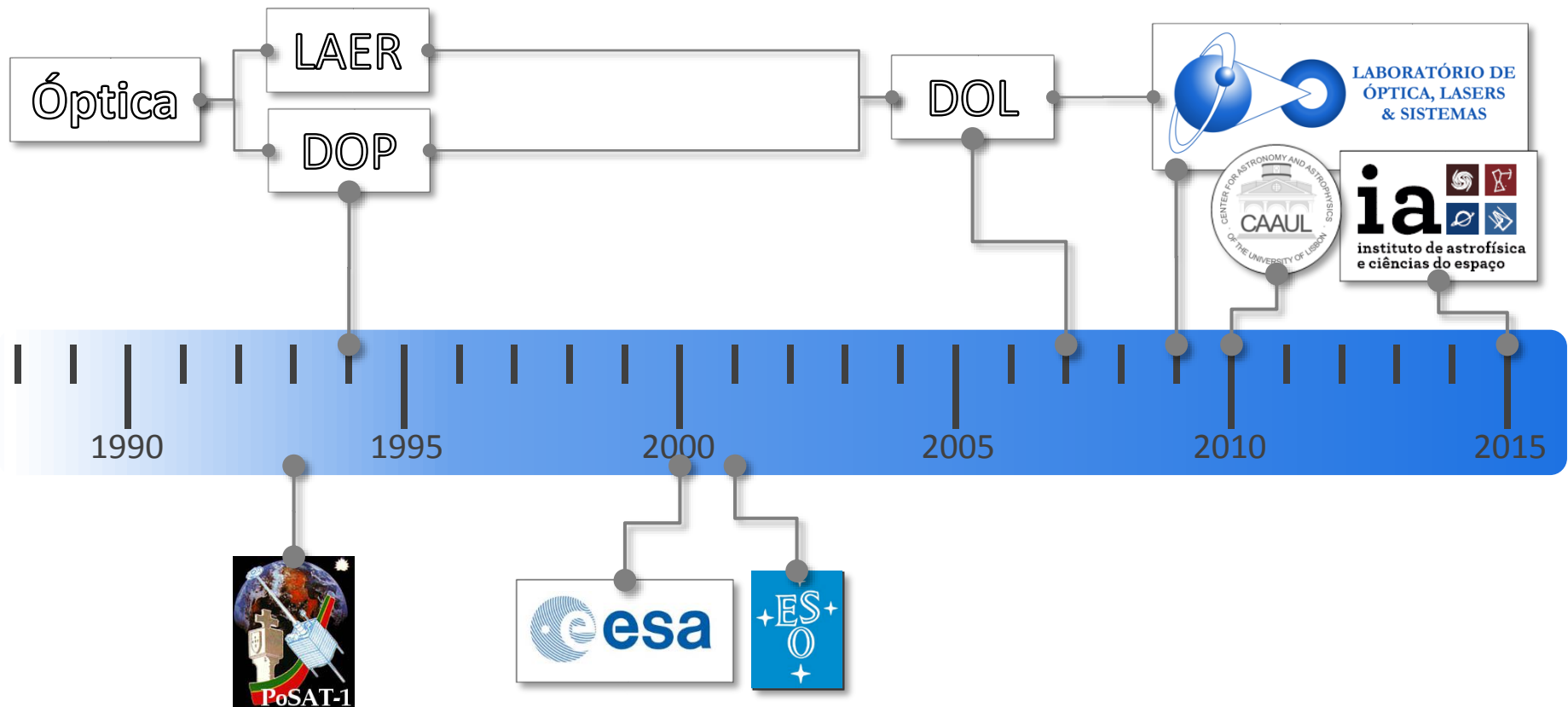

Research Group  
**Instrumentation & Systems**

# Background of the I&S Group



# Background of the I&S Group

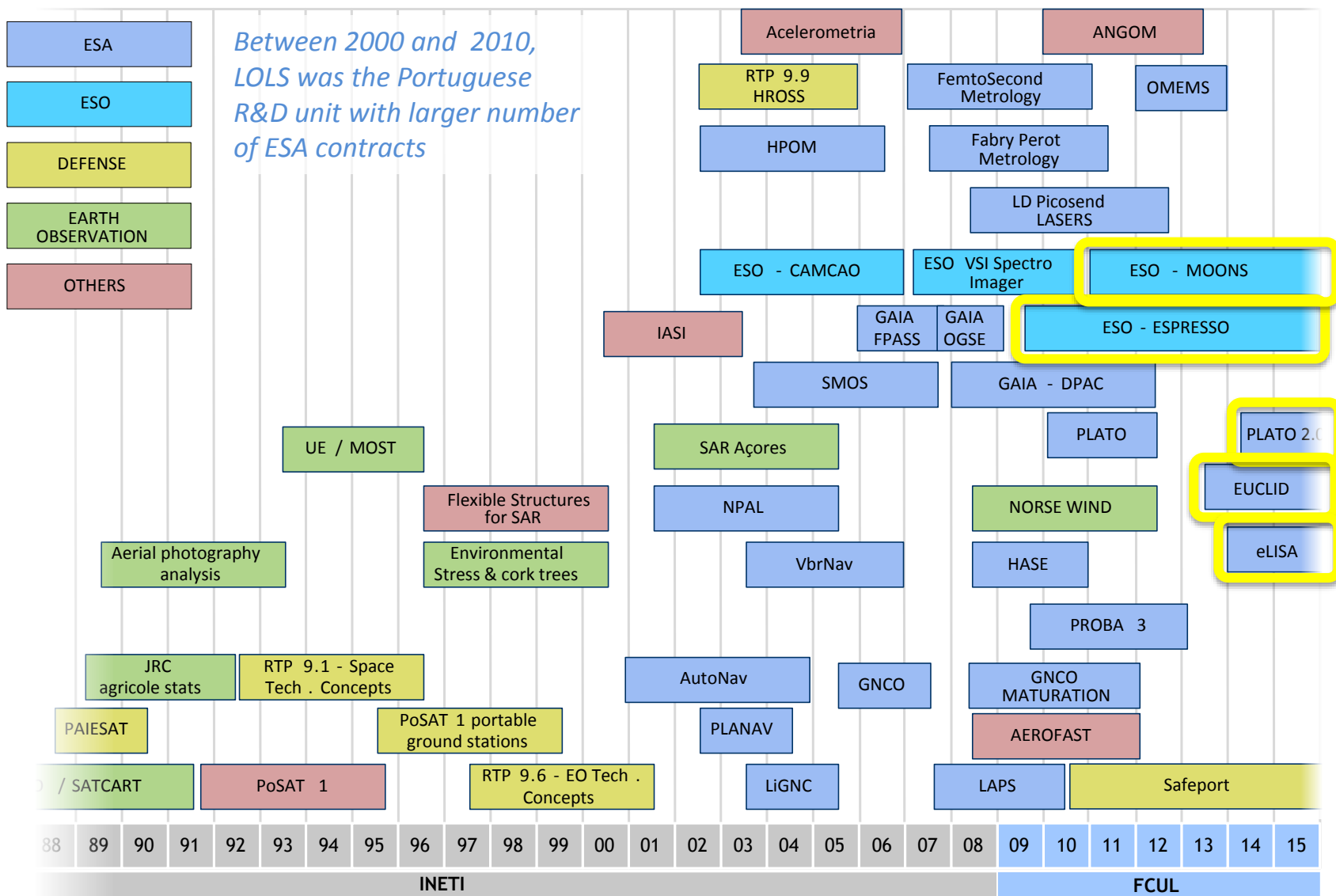

# Expertise of the I&S Group

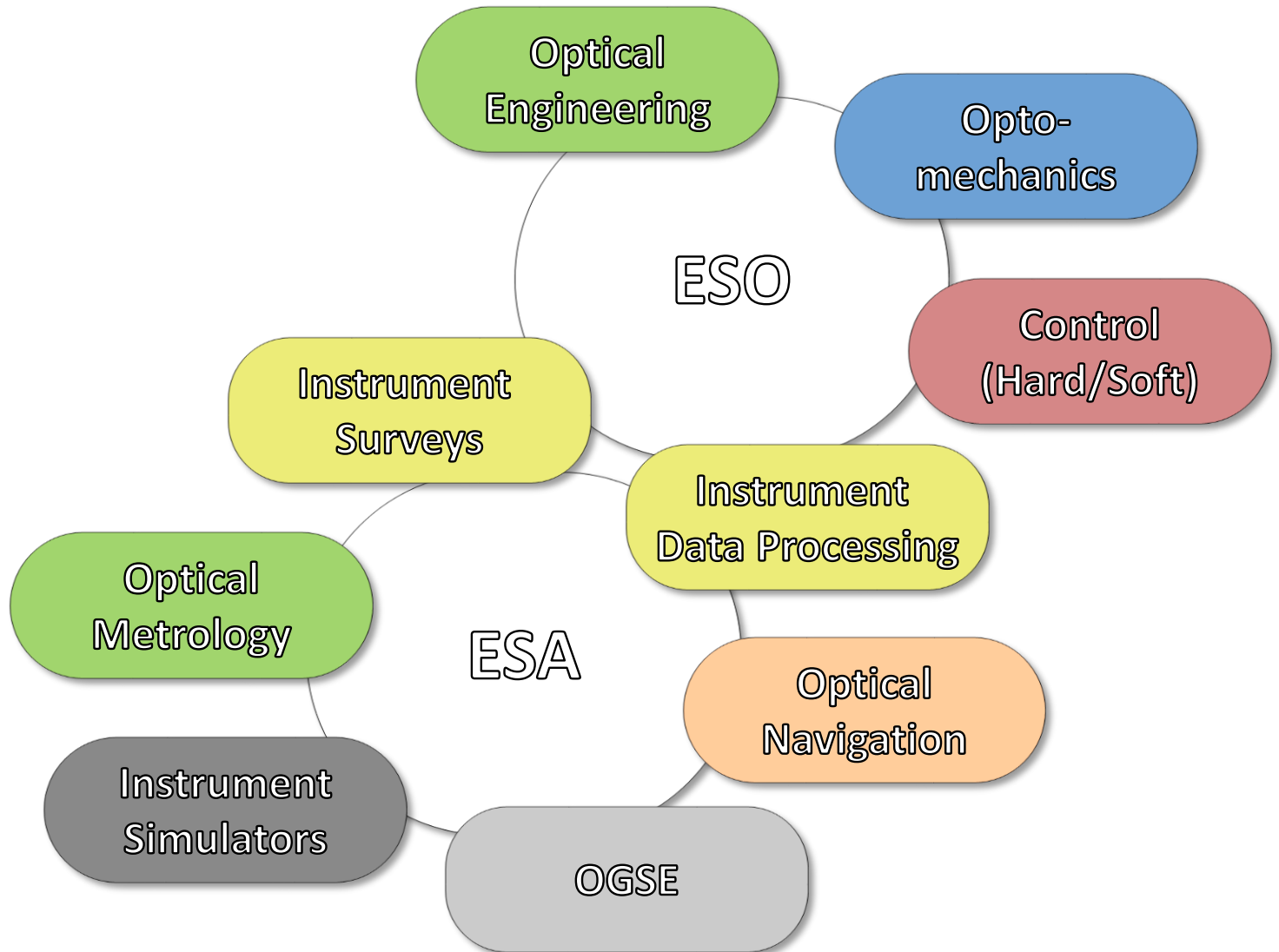

# I&S Group Resources

- The I&S Group has access to a valuable laboratory infrastructure (~400 m<sup>2</sup> – FCUL/LOLS) and covers the complete instrumentation chain, from concept to data pipelines and surveys
- ISG is currently composed of:
  - 11** researchers (PhD),
  - 6** engineers and
  - 3** PhD student

# I&S Group Human Resources

<u>Alexandre Cabral</u>	<i>Integrated Member</i>
<u>António Oliveira</u>	<i>Engineer (LOLS)</i>
<u>Catarina Silva</u>	<i>Engineer</i>
<u>João Coelho</u>	<i>Colaborator</i>
João David	<i>Engineer</i>
<u>Mahmoud Hayati</u>	<i>Engineer</i>
<u>Manuel Abreu</u>	<i>Integrated Member</i>
<u>Pedro Santos</u>	<i>Engineer (LOLS)</i>
Elena Duarte	<i>Integrated Member</i>
José Manuel Rebordão	<i>Integrated Member</i>
<u>Manuel Monteiro</u>	<i>Engineer</i>
António Silva	<i>Integrated Member</i>
Carla Sofia Carvalho	<i>Integrated Member</i>
Ismael Tereno	<i>Integrated Member</i>
João Dinis	<i>Integrated Member</i>
Pedro Figueira	<i>Integrated Member</i>
Sérgio Sousa	<i>Integrated Member</i>
Solène Ulmer-Moll	<i>PHD Student</i>
David Alves	<i>PHD Student</i>
Tiago Magalhães	<i>PHD Student</i>

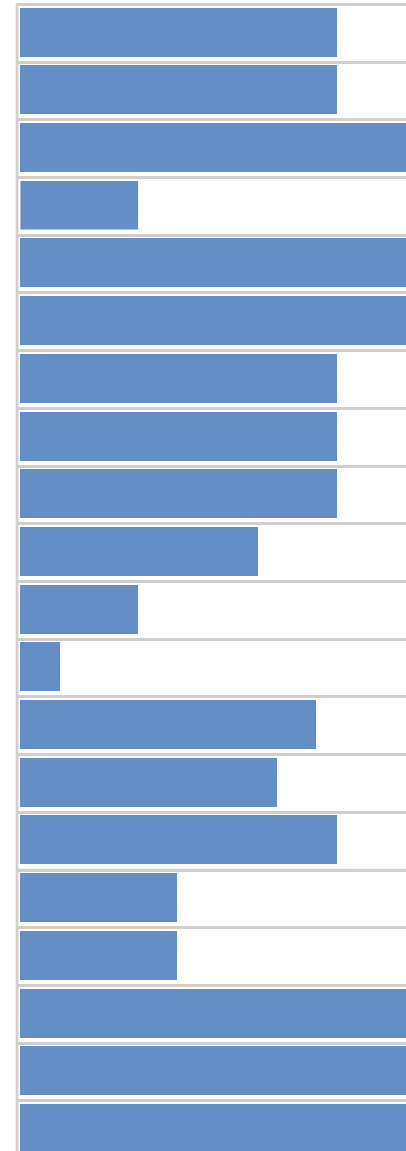

# I&S Group Projects

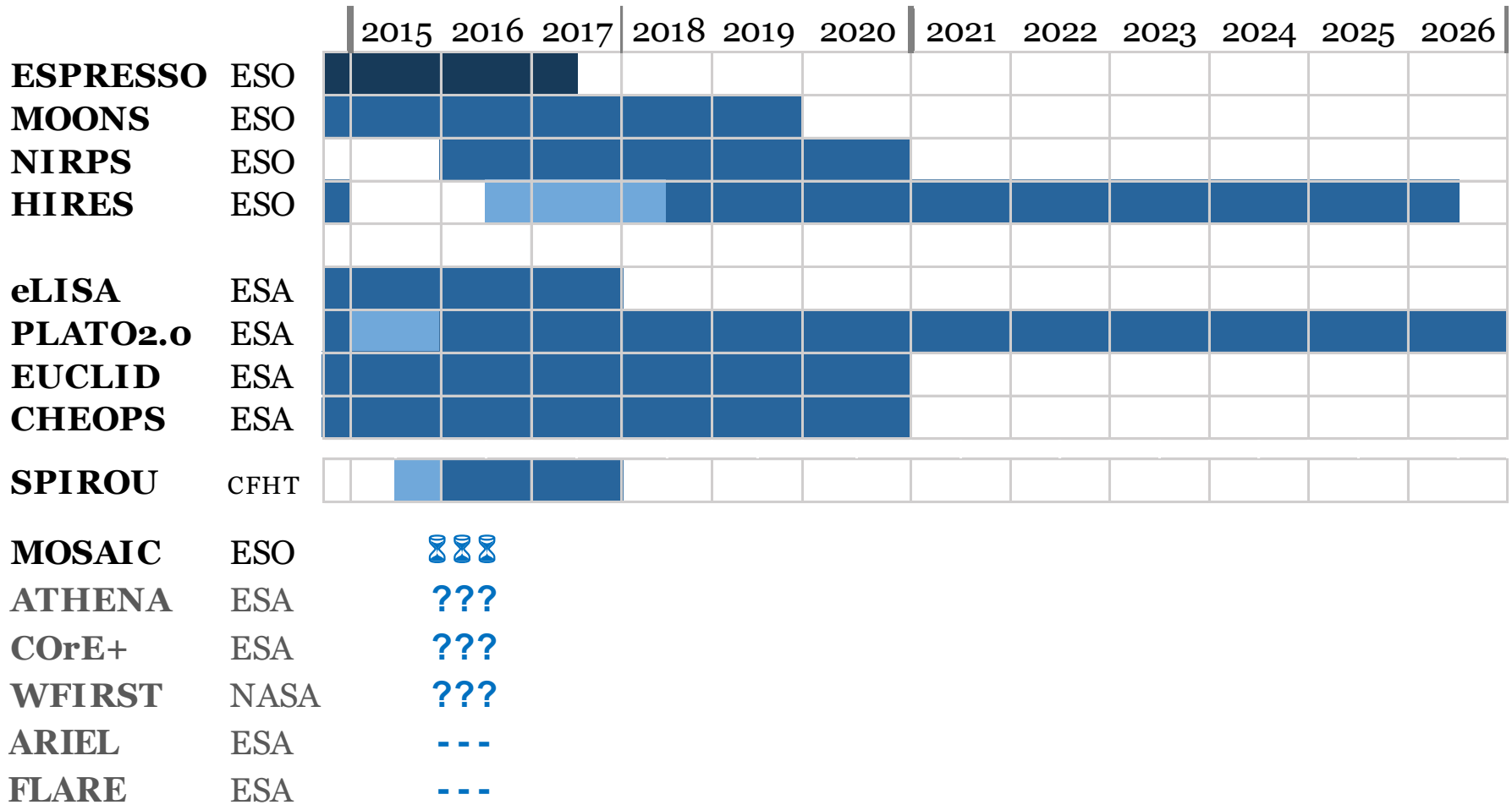



**instituto de astrofísica  
e ciências do espaço**

# .....Running Projects



**euclid**

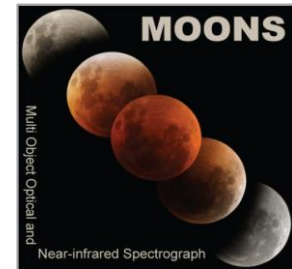



# IA ESPRESSO Contribution

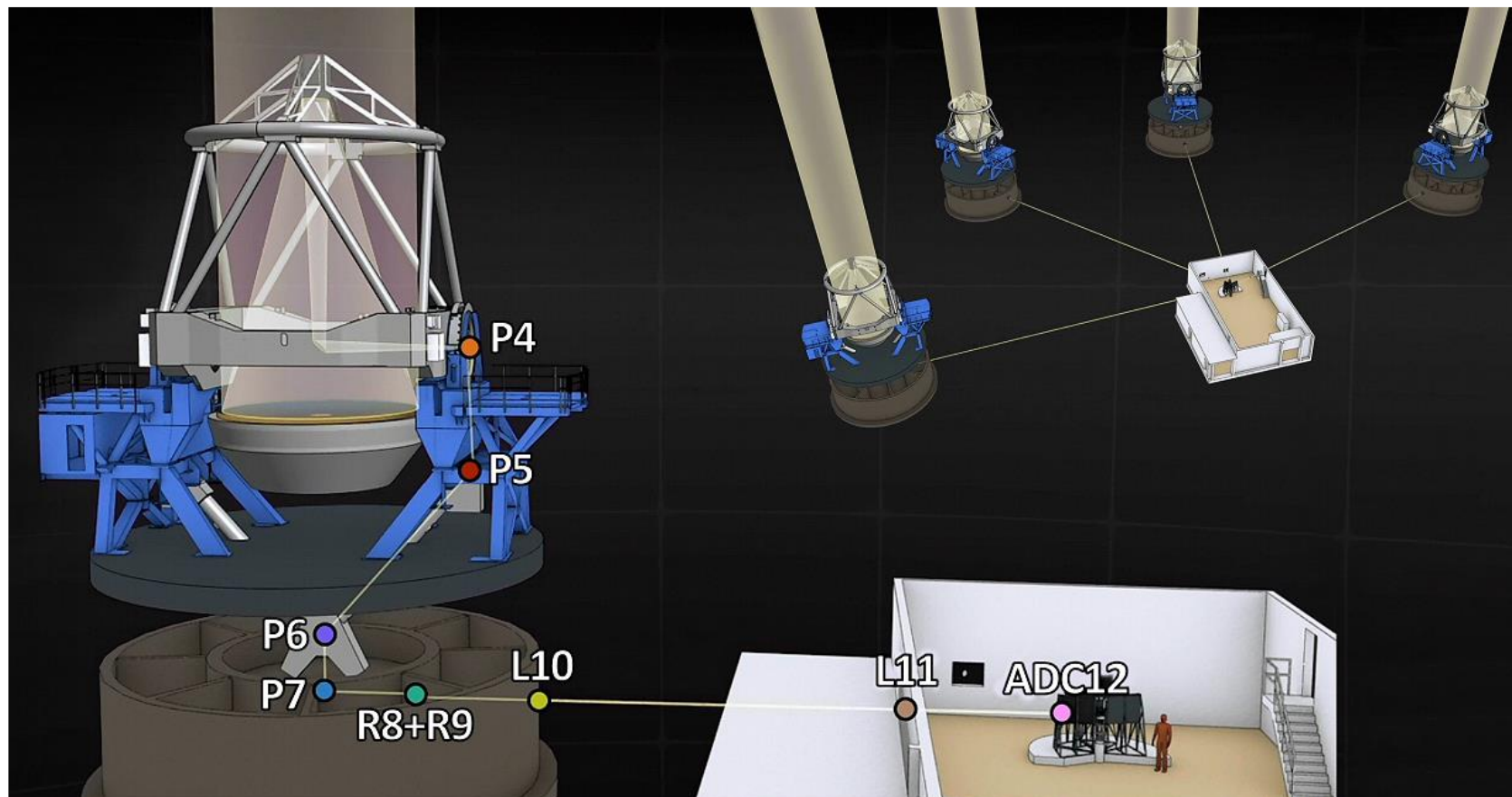

# ESPRESSO Timeline

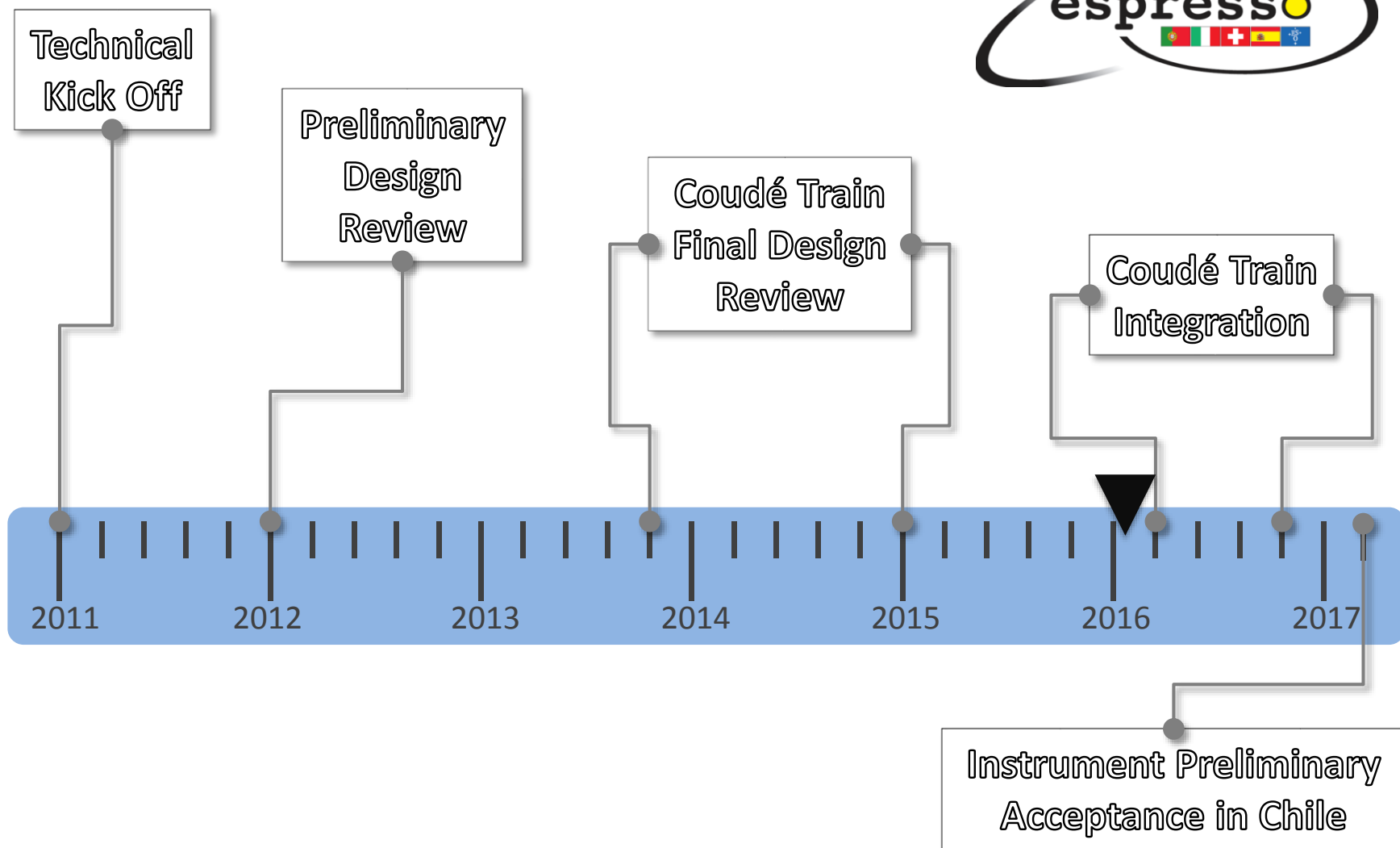

# Instrument in a nutshell

Parameter	Specifications
Telescope	VLT
Field of View	500 arcmin <sup>2</sup>
Multiplex	1000 objects, with possibility to deploy fibre pairs (500 obj+500 sky)
Sky-projected diameter of each fibre	1.0 arcsec
Close packaging	At least two fibres within 10 arcsec
Wavelength coverage	0.65 - 1.8 $\mu$ m
Observing modes	Medium (MR) and high resolution (HR)

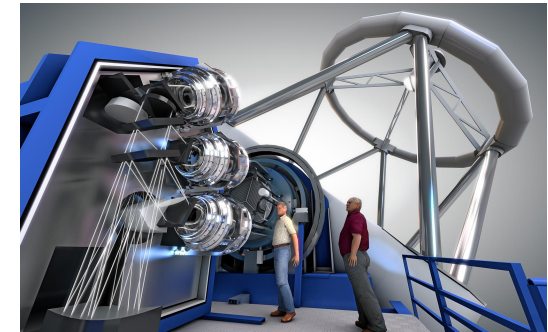
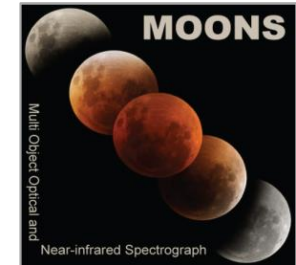

Observing Mode/Band	Spectral coverage	R (at central $\lambda$ )	Comment
MR-RI	0.647 – 0.955 $\mu$ m	4,100	Simultaneous in MR mode
MR-YJ	0.934 – 1.350 $\mu$ m	4,300	
MR-H	1.452 – 1.800 $\mu$ m	6,600	
HR-I	0.765 – 0.898 $\mu$ m	9,200	Simultaneous in HR mode
MR-YJ	0.934 – 1.350 $\mu$ m	4,300	
HR-H	1.521 – 1.641 $\mu$ m	18,300	

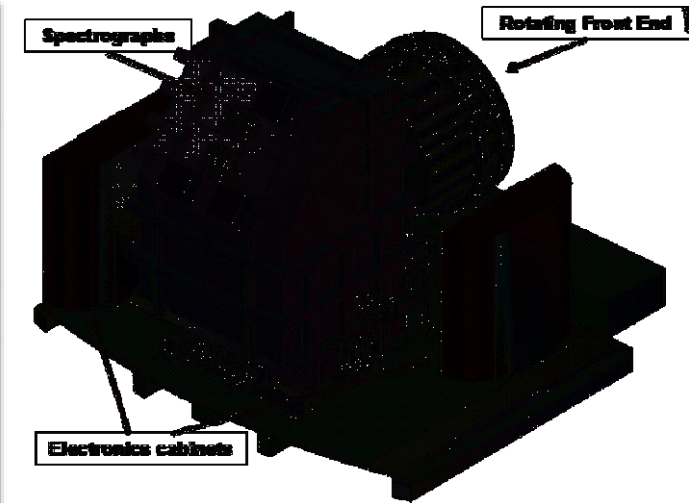

# IA MOONS Contribution

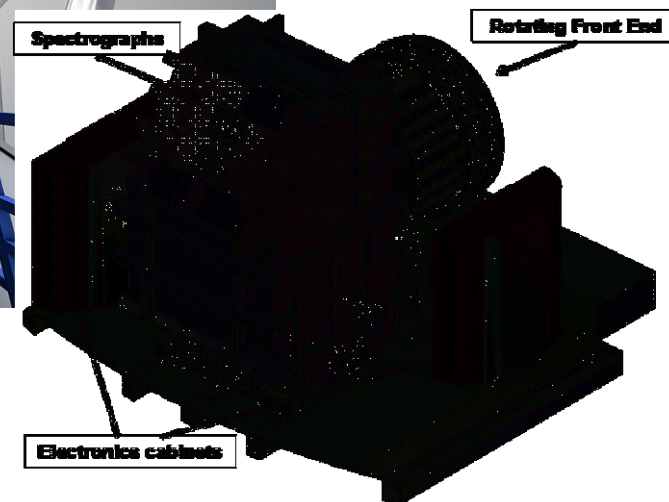
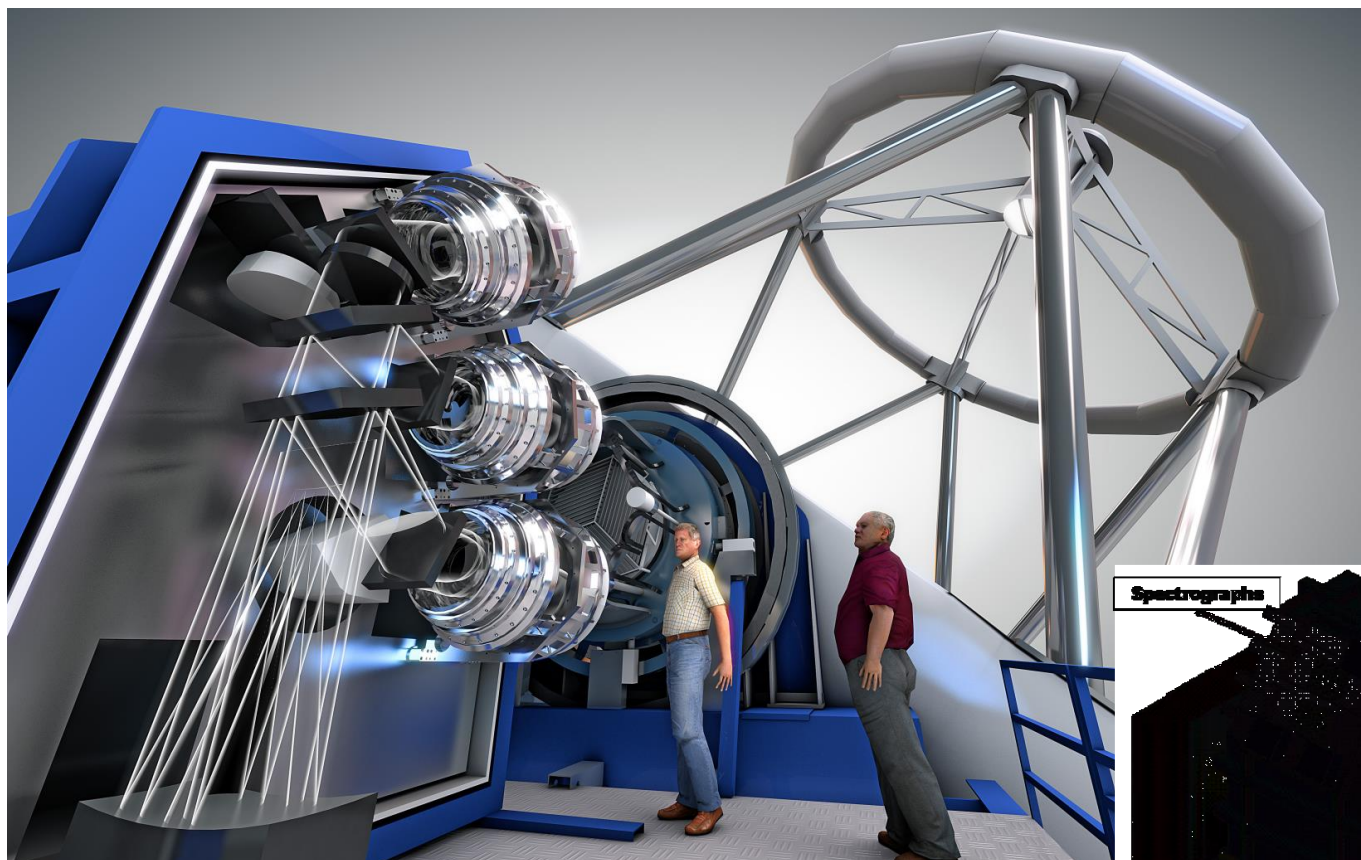
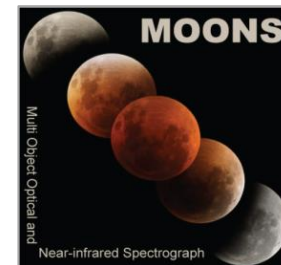



# IA MOONS Contribution

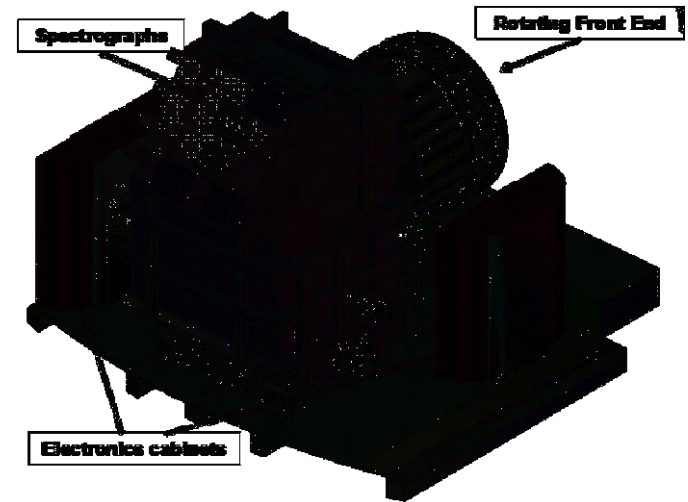
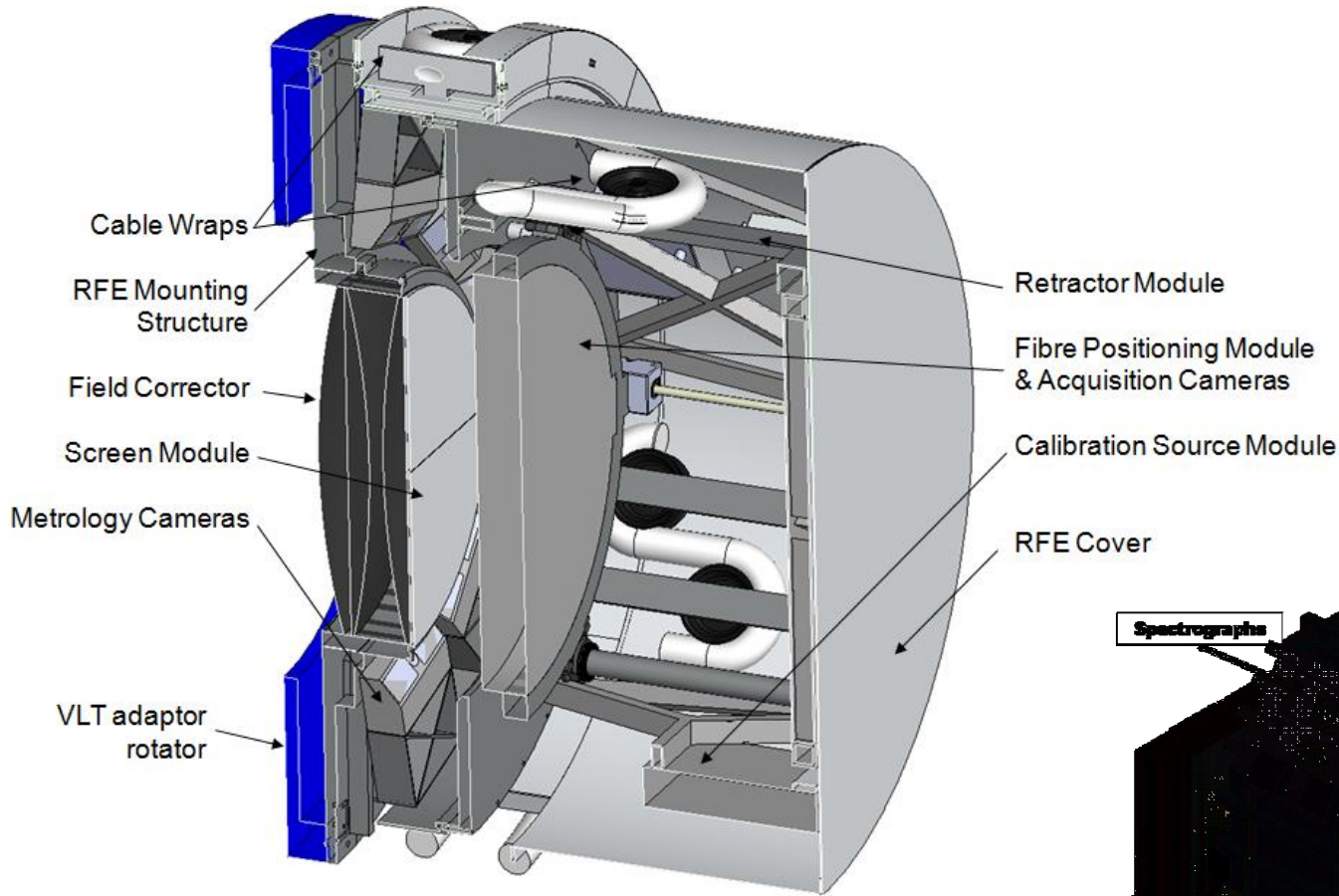

# MOONS Timeline

